

Operate area

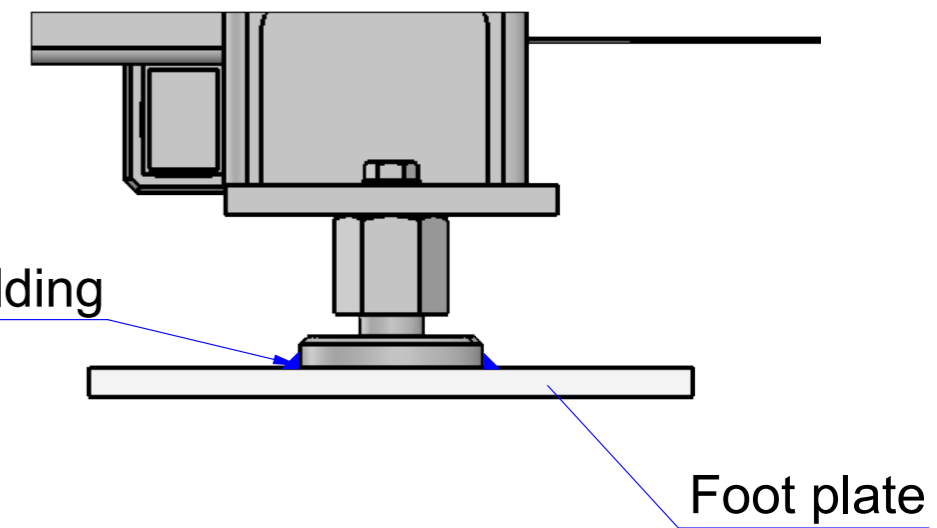

### Installation Method

1. Make foot plate first, base on above picture size.
2. With expansion bolts fixed the foot plate to the concrete floor. Expansion bolt dimension: M12\*100 , 32pcs
3. Put machine onto the suitable foot plate, then weld the machine with foot plate together.
4. In principle, it is required 8pcs of the floor plate fixed on concrete of 400\*400\*600mm depth column, and then the foot plate fixed on the concrete surface. If the strength of the concrete surface is sufficient, the floor board can be directly installed on the concrete floor as the foundation.

品番 PRO. NO.	SUNMAX-FL3015CN	FL3015CN-基礎図面		図番 DRAFT NO.	FL3015CN-
設計 DES. BY	2018/6/16			品名 PRO. NAME	レーザー切断機
確認 CHECKED		記述 DESCRIPTION	尺度 SCALE	1 : 25	
承認 APPROVED		材質 MATERIAL	組立 WEIGHT	1152327.16	
Sunmax Laser , Japan					